

Fusion Flush Mount

Low-Profile Table-Mount Fusion Console



4-Channel



5-Channel



8-Channel



12-Channel

Quick Start Setup Guide

For part numbers: 2001-00479, 2001-00480, 2001-00481, 2001-00482, 2001-00483,
2001-00484, 2001-00485, 2001-00486

ATTENTION!

This quick start guide is intended to aid with basic deployment of Fusion Flush Mount.
For further support and/or questions please contact support@telosalliance.com



IMPORTANT SAFETY INFORMATION ABOUT YOUR NEW PRODUCT

We know you're eager to get your new gear up and running. But first, The Telos Alliance strongly suggests you use an Uninterruptible Power Supply (UPS), with power line filtering, to prevent damage in case of electrical storms or power surges. Your Product Warranty (found in the User Manual) does not cover lightning damage!

Information about lightning protection can be found at:

<http://blogs.telosalliance.com/tech/surge-suppression-pointers>

Quick Start Setup Guide

Assembly

Each Fusion Flush Mount (FFM) “bucket” can be joined to another with three M4 thread forming pan head screws provided (p/n :1301-00100) .

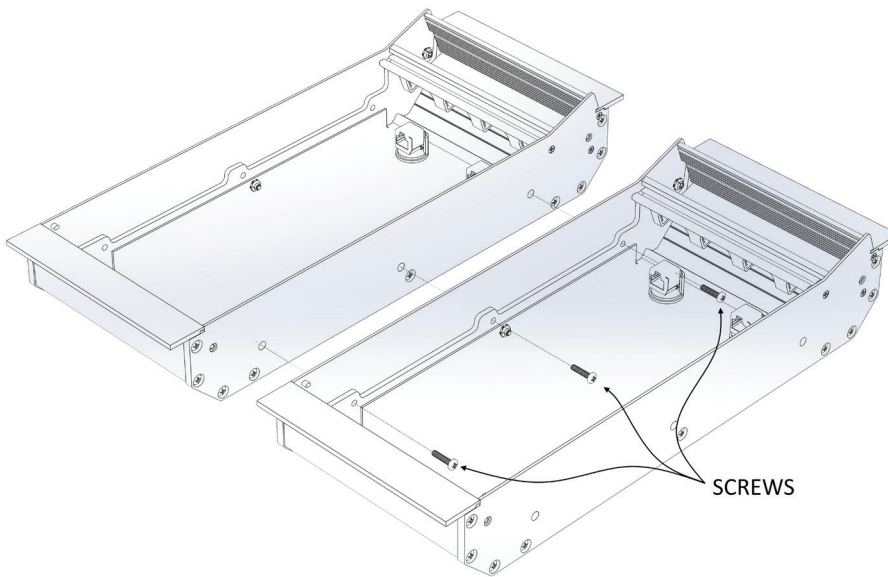

The final assembly of buckets would have a “wing” set (p/n:2001-00483) installed on either side with four M4 thread forming pan head screws provided (p/n:1301-00100) .

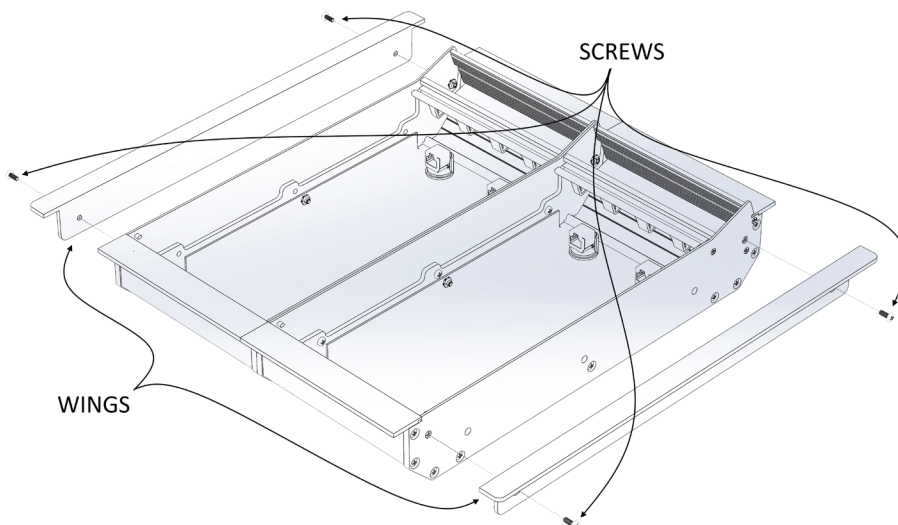

The complete assembly would drop into a cutout made in the table top. The cutout dimensions will depend on which tub sizes have been used and the desired fit. The table below provides some numbers to help calculate the dimensions.

Size	Width	Height	Depth
4-Chann bucket	182.7 mm [7.19 in]	433.3 mm [17.06 in]	78.2 mm [3.08 in]
5-Chann bucket	227.3 mm [8.95 in]	433.3 mm [17.06 in]	78.2 mm [3.08 in]
8-Chann bucket	360.7 mm [14.20 in]	433.3 mm [17.06 in]	78.2 mm [3.08 in]
12-Chann bucket	538.6 mm [21.20 in]	433.3 mm [17.06 in]	78.2 mm [3.08 in]

Note that the side wings provide a typical 9.5 mm [0.37 in] addition to the width.

The lip provides on all four sides a 17.2 mm [0.68 in] typical cover.

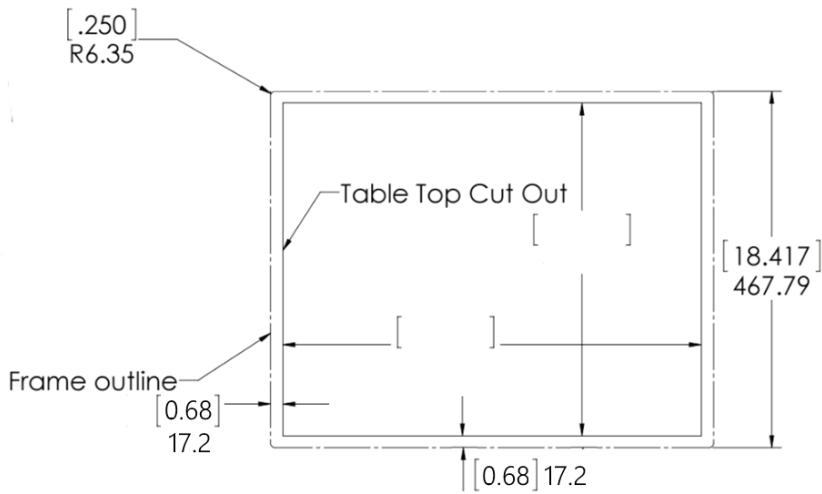

The FFM Interface housing (p/n:2001-00484) is design to mount underneath the table top in proximity to the assembled buckets.

Connections

The FFM Interface housing has two power inputs and a network port on one side. The opposing side has 4 module connection ports and a single 6-pin molex which is used for special cases (not needed here).

Connect each of the buckets to one of the 4 module connection ports. The module connection ports may have a termination plug which would be removed and applied to the last module in the line. Within each FFM bucket, modules within buckets can be connected in a series. It is recommended to have three or less modules within a series. Each bucket will have connection ports on the underside. You may daisy chain buckets if needed for your application but should follow the three module guideline and setting a termination at the end of a chain.

Connect the network port (labeled Livewire) to a configured network switch. Connect the power supply to one of the two power inputs. If redundant power supply is being used, connect the second power supply as well.

FUSION FLUSH MOUNT FRAME DIMENSIONS
 1. DIMENSIONS IN MILLIMETERS [INCHES]

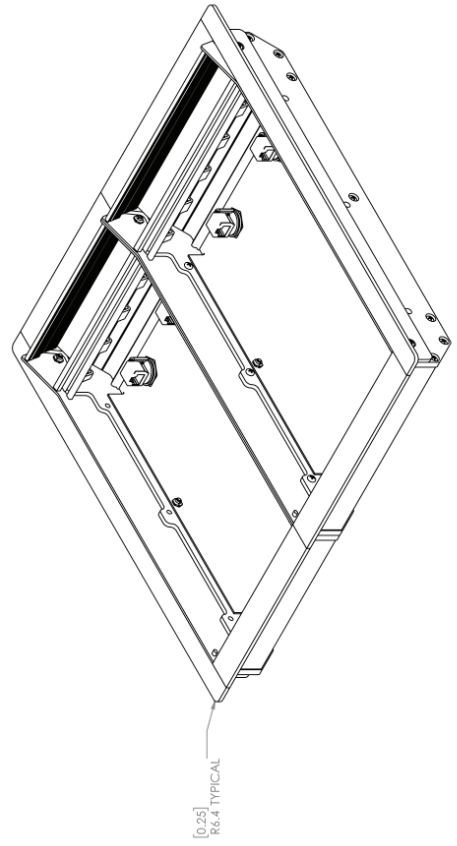
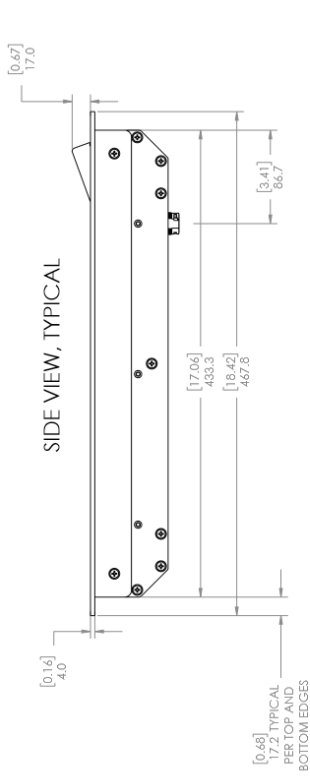
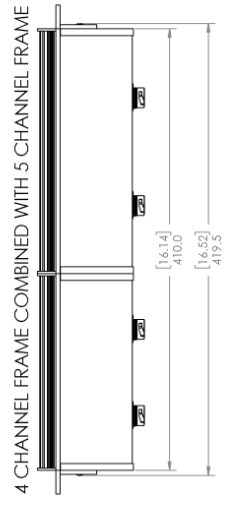
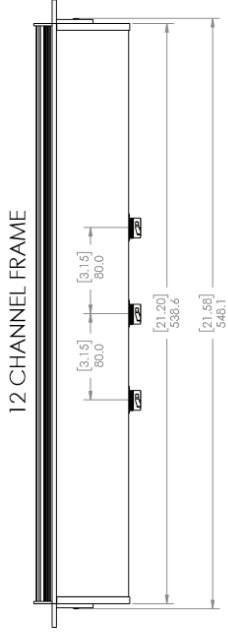
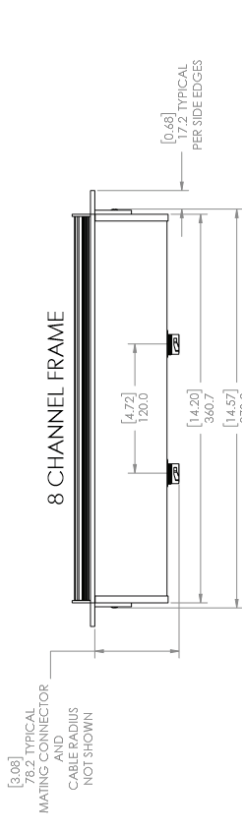
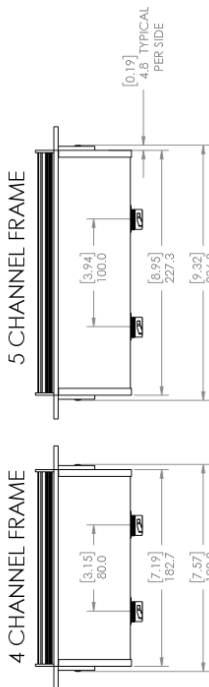

COMBINED 4 CHANNEL AND 5 CHANNEL FRAME



Telos Alliance Limited Warranty

Telos Alliance Radio Division has an industry-leading five-year warranty. As a company, we are committed to our products and the pursuit of providing better quality to our customers.

Find the Warranty online at www.telosalliance.com/warranty.



THE TELOS ALLIANCE®

The Telos Alliance • 1241 Superior Ave. • Cleveland, Ohio 44114 USA • +1.216.241.7225 • TelosAlliance.com

© 2017 TLS Corp., All Rights Reserved. C17/16045 P/N: 1490-00175-002